



SEPARATING PEOPLE FROM HAZARDS

# Collective Fall Protection Solutions



- PERMANENT AND TEMPORARY PORTABLE OPTIONS AVAILABLE
- INDEPENDENTLY TESTED, MEETS OR EXCEEDS SAFETY STANDARDS
- NO WELDING, BENDING, OR THREADING OF PIPE
- GALVANIZED FINISHES MAKE INSTALLATIONS VIRTUALLY MAINTENANCE FREE



CSI 077200  
June 2011



Independently tested to  
OSHA Standard 29 CFR 1910.23  
Ontario OHS Act  
Meets ANSI Standards



# the fall protection solution

At KEE SAFETY, our specialty is railing solutions. For over 75 years, we have been designing our quality components and barriers for safety solutions. We strongly believe that our railing solutions provide maximum fall protection for your people at heights. When you need a safe, reliable, durable and versatile fall protection solution, choose KEE SAFETY.

## Fall Protection Survey

We can provide a complete turn-key fall protection solution for you. The process starts with the Fall Protection Survey which involves a site visit to your facility.

From the survey, we will develop a custom Fall Protection Survey Report to inform you of areas of safety concern. The report, complete with color photographs, conveys our recommendations of how to address these areas and includes references to all relevant safety regulations. If you would like, we can include risk assessment of all your existing fall hazards.

After the areas of safety concern are evaluated, we will give you a materials quotation for any fall protection solutions we recommend.

## Installation

Installation can be done by our team or your own. If you choose our team, installation will

be charged accordingly. If you decide to install the system yourselves, we can provide you with the shop drawings that show the locations of all the components. We can provide training for your installation team to communicate all of the necessary recommendations to complete the installation correctly. This training can be done at your own facility or at our training center in Buffalo, NY.

## System Certification

We offer an optional Certified Installation Service which consists of a site visit after the installation is complete. You will receive a report that describes the installation and denotes any corrections that need to be made for the most effective fall protection. When the installation is completed correctly, you will receive a certificate confirming manufacturer approval.

## We set the standards

- OSHA Standard 29 CFR 1910.23
- OSHA Standard 29 CFR 1926.501, CFR 1926.502
- Canadian National Building Code 4.1.10.1(1)(e), 4.1.10.1(2), 4.1.10.1(4)
- Ontario Building Code Section 4.1.10.1(1)(b), 4.1.10.1(2), 4.1.10.1(4)
- HSG-33 Health & Safety in Roof Work
- HSE Specialist Report No 15: 1988
- HSE Sheet 21 "Working on Flat Roofs Protection Against Falls"
- BS 6399: Part 2 1995 Wind Code
- EU Directives & CDM Regulations
- BGV A1: 2000, BGG 928 & BGR 184
- Health, Safety & Welfare Regulation 13 "Falls or Falling Objects" 1992
- NFE 85-003
- EN ISO 14122: PT3
- EN 13374
- International Building Code 2006
- ANSI/ASSE A1264.1-2007 Standard
- Wind load tested
- Earthquake & collision results

## Warranty

Our standard warranty on all fall protection components is one year. We also offer an extended warranty service to be purchased additionally, which can consist of up to a five-year warranty on all of the components. This extended warranty includes a site visit within one year following the completion of the installation. During the site visit, the installation will be inspected and recommendations will be made for other areas of safety concern, if applicable.





## Safety

KEE SAFETY Fall Protection Systems not only meet, but exceed current safety requirements for maximum rooftop fall protection. KEE SAFETY Fall Protection Systems use components that are TÜV tested and approved. System components are fitted with anti-slip rubber pads for safety and to protect the roof membrane. Integral toe board may be added for full health and safety compliance.

## Durability

KEE SAFETY Fall Protection Systems use components that are galvanized, providing long lasting rooftop fall protection you can depend on. All pipe is galvanized to ASTM A53. All components are galvanized to meet the requirements of BS EN ISO 1461:199. Our systems utilize reliable KEE KLAMP components which provide strong, rigid, virtually maintenance free connections, featuring case hardened steel set screws with KEE KOAT corrosion resistance.

## Versatility

KEE SAFETY Fall Protection Systems employ a pre-fabricated modular design that allows you to reconfigure your system on site, with ease, if needed. Sections can be added to, or taken down and assembled on site. A variety of uses include skylight protection, walkway demarcation, stairwell protection and more. Our solutions are compatible with almost all variations of flat roofs (up to 5 degrees), be they circular, square, rectangular or multilevel. All products are available from our warehouse or through authorized installers.

## Simplicity

KEE SAFETY Fall Protection Systems have a unique modular design that takes the complexity and cost out of rooftop fall protection. Minimum number of components eases installation. No drilling, special anchoring or penetration of the roof membrane. No welding, bending or threading required on site, and no specialty tools are needed.

## OSHA Compliant

The KEE KLAMP components, and specially designed KEE-GUARD components, when used to construct the KEE-GUARD Railing System, a 42" high guard railing, will meet or exceed the requirements of the OSHA Safety Standard of a single 200 lb. load applied at any location and in any direction along the top of the rail when the correct specification of pipe is used and the correct method of design is employed. The integrity of the structure to which the system may be attached and the fixings used may need to be reviewed by a structural engineer to ensure they will meet the imposed load requirements.





permanent, free standing  
roof edge railing system that  
does not penetrate the roof  
membrane

## KEEGUARD Counterbalance Assembly

CB4 and CB3 assemblies are used for end uprights when there is no tie into the building or at the end of a run over 13 feet. For runs less than 13 feet, please contact us.

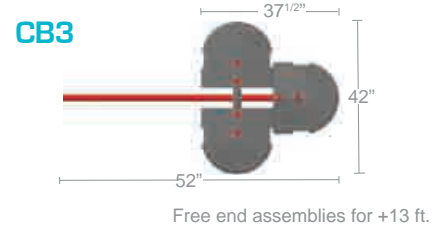
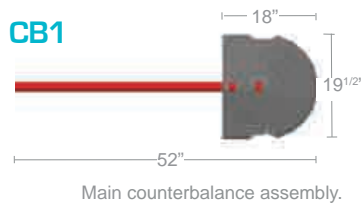

### Recycled PVC Counterbalance

- Each CB weighs 30 lbs
- Carrying handles molded into design
- Reflective labels on each weight
- Surface promotes traction and grip
- Made from 100% Recycled PVC
- Size: 18 x 20 x 3 inch

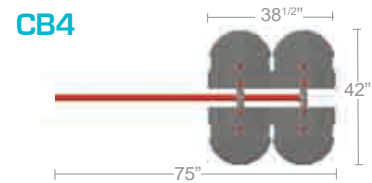

## KEEGUARD Main Upright

Our KEEGUARD uprights are preassembled for fast on-site installation.

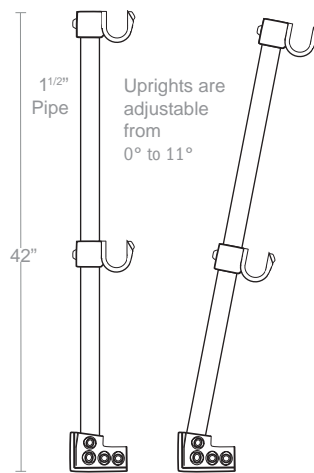

### 135-8

An open style crossover component allows for fast installation of horizontal rails.



### Toe Board

Toe board option is available when required.



### Base

Base component has an anti-skid rubber pad pre-applied. Engineered weep hole in the base allows water to drain.



## KEE KLAMP Components

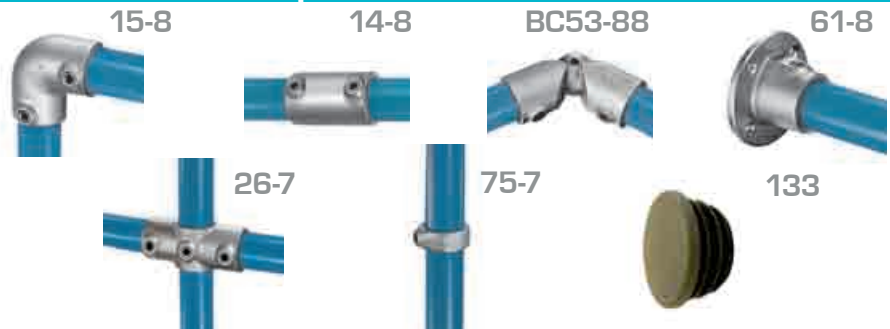

KEE KLAMP components make the basic building of KEEGUARD configurations straightforward and versatile. The components above are the most commonly employed in KEEGUARD fall protection systems.



## KEEGUARD Drawings

Examples of D-returns, wall attachment, and parapet protection. Just contact the KEEGUARD engineering team at KEE SAFETY for custom configurations and technical assistance.

- Use CB4 and CB3 assemblies for end uprights not attached to the building
- Dimensions of D-Return and distances between uprights are maximum allowable distances

**Fig. 2**

Wall attachment

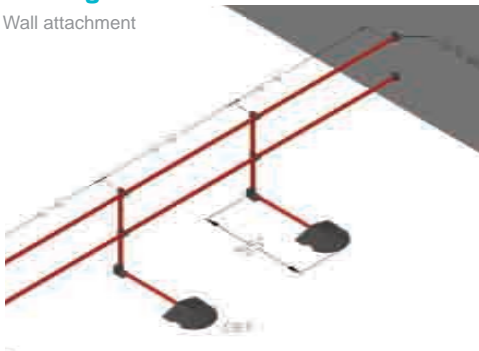

**Fig. 4**

16' Straight  
Unrestrained

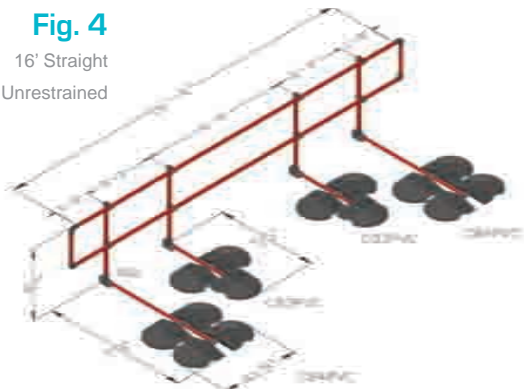

**Fig. 1**

Straight 29' run  
with D>Returns

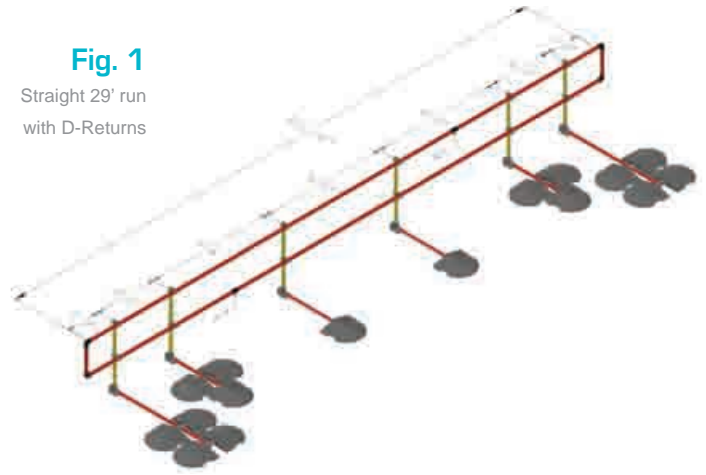

**Fig. 3**

L-shaped 29'x13'  
with D>Returns

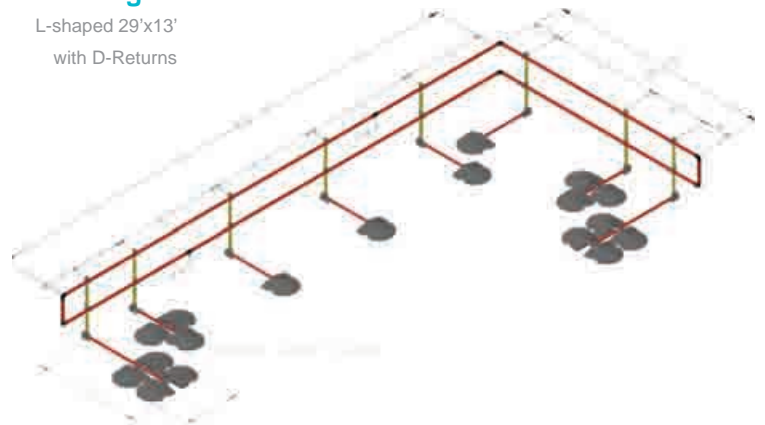

**Fig. 5**

16' -4" Straight  
Restrained

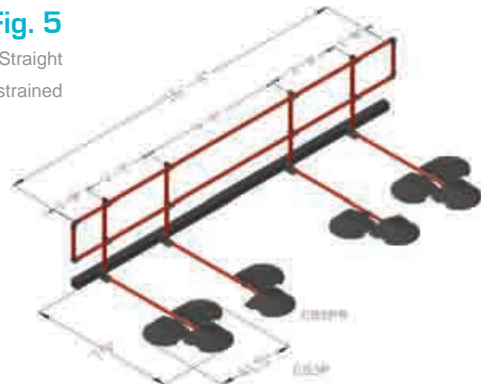

Sold only as a complete system.

## Custom Color

The KEEGUARD PVC counterbalance is available in the standard color gray. KEEGUARD PVC counterbalances can also be customized in colors such as orange, blue and yellow. Please contact KEE SAFETY for details concerning custom colors.



# standing seam



Here at KEE SAFETY, we've put together a unique railing system for standing seam metal roofs system that is OSHA compliant. This custom designed guard rail provides proper access to rooftop equipment for maintenance or inspection, provides any needed perimeter protection, and also accommodates proper ladder access. With our standing seam systems, there is no drilling, special anchoring or penetration of the roof. No welding, bending or threading on site, and no specialty tools are needed. It doesn't get any easier than that!

## Versatile

The use of KEE KLAMP components enables KEEGUARD to meet unique design requirements and non-standard applications. The horizontal baseplates are custom fabricated to meet the exact specifications of your standing seam metal roofs.

**Fig. 1**

KEEGUARD standing seam 24' run with d-returns

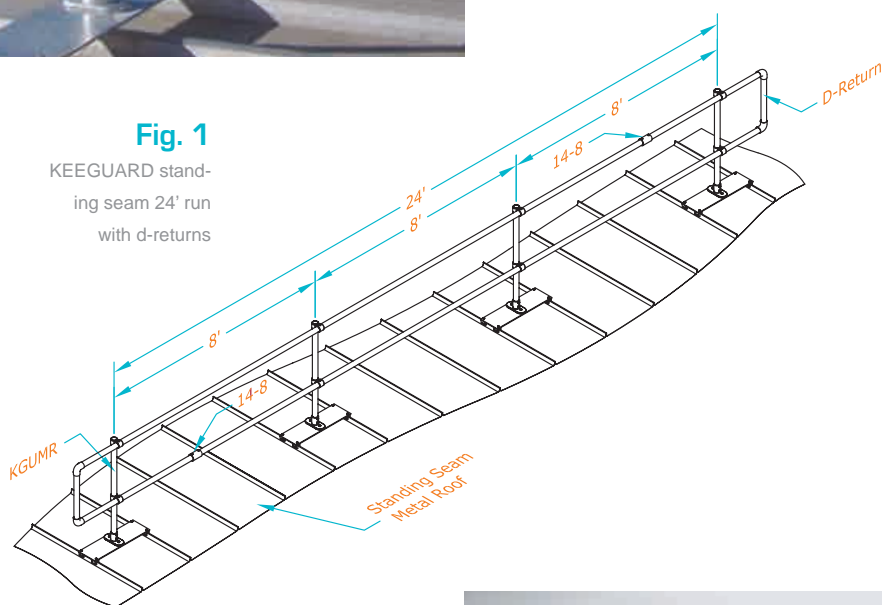

**Fig. 2**

KEEGUARD standing seam upright assembly

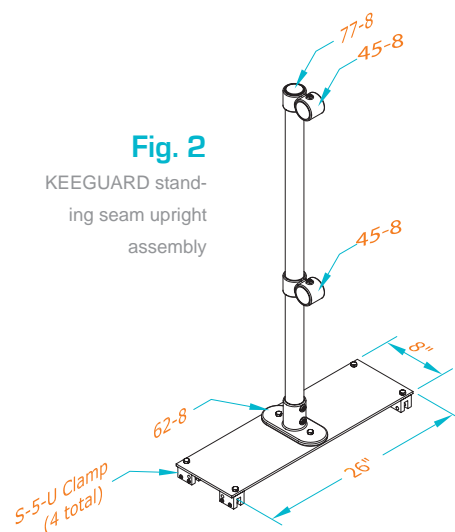

## Configuration

Four S-5U clamps are bolted to a galvanized steel base plate, and using simple set screws, the S-5U clamps attach securely to the standing seams without puncturing the metal roof. A KEE KLAMP Type 62 component affixes to each metal base plate in the system to support the uprights. Our open-style crossover component, Type 135-8, speeds installation of horizontal rails on all KEEGUARD Fall Protection Systems. All components are galvanized for corrosion resistance and minimum long term maintenance.



Sold only as a complete system.

# Contractor

## KART-A-RAIL

Makes transport and storage of the entire KEE-GUARD CONTRACTOR system easy. Large eyelets on the frame allow for simple attachment of belts and bungees to keep rails in place. A smaller handcart is also available.



## Portable Roof Edge Protection

Kee®  
Guard

CONTRACTOR

KEEGUARD Contractor offers a new and innovative approach to portable and temporary railing systems. Since the system is free standing, there is never a need for hardware connections to the rooftop or working surface. KEEGUARD Contractor meets all OSHA Standards for permanent railings, including OSHA Standard 29 CFR 1926.500 with returns in place. (As shown below) Fig. 1



Fig. 1

KEEGUARD  
Contractor configuration

Fig. 2

KEEGUARD  
Contractor handcart

## Configuration

The uprights are secured in the bases by set screws, making the system as solid as permanent railing. Assembly is made simple by using a torque wrench or hex key. A railing section consists of two uprights and two horizontal rails. The minimum system configuration consists of three railing sections and four base plates, all with a galvanized finish ensuring a long life of the system. Powder coating in safety yellow is available.

Sold only as a complete system.

## Contractor Base Plate

- Strong, galvanized finish
- Rubber pad underside to protect roof membrane
- Four upright sockets make almost any perimeter configuration possible
- 98 lb. base ensures stability
- Ergonomically designed handles
- Complete with slots for optional 2"x 6" toeboard

# Kee® Mark

Kee®  
Mark

## Demarcation

KEE MARK is a sturdy, durable, and cost effective portable warning line, for indoors and out. The simple modular design incorporates durable galvanized KEE KLAMP components and galvanized uprights that stay in place with a hidden set screw. The heavy-duty nylon mesh flags are available in safety orange or safety yellow. The stainless steel wire cable is vinyl coated for long term outdoor use in safety yellow for greater visibility. The cables are connected to the uprights with stainless steel shackles which makes adjusting the layout very easy. The removable bases are made of solid heavy duty recycled rubber. KEE MARK is a demarcation solution that is engineered to stand its ground, job site after job site. Meets OSHA standard for warning lines.







safety barrier system for safe egress and ingress through hatches in roofs or floors

## The Safety Solution for Hatches

The KEE HATCH safety railing system is designed for safe egress and ingress through roof access hatches and for protection of the roof opening while the hatch is open. Our new safety gate ensures protection around the entire opening. KEE HATCH is designed as a compliment to our KEEGUARD Roof Edge Protection System to provide a complete OSHA compliant, durable, and long lasting solution. KEE HATCH is engineered in the USA and meets the most stringent safety standards.



### Simple Design

Our design concept is simple: use strong structural tube and KEE KLAMP components. This simple concept makes our KEE HATCH systems flexible enough to fit any hatch configuration. We only use galvanized fittings and pipe so that your rooftop system is corrosion resistant and built to last.

- Modular construction speeds installation
- Galvanized finish for corrosion resistance
- Rails serve as grab bars for easy roof access

### Easy Integration

We have designed seven different solutions that are suited to fit any hatch. KEE HATCH is designed as a compliment to our KEEGUARD Roof Edge Protection System, but it also integrates beautifully into any existing rooftop systems because of its unrivaled versatility.

- 7 versatile systems available
- Compliments KEE GUARD Roof Edge Protection
- Integrates easily with existing openings and ladderways

### OSHA Compliant

KEE HATCH meets OSHA standards 29 CFR 1910.23 and 29 CFR 1910.66. The former requires that the exposed sides of openings in roofs or floors have some form of guardrail protection. When the hinged cover for an opening is left up, the exposed sides must be appropriately protected.

- Exceeds minimum strength requirements for railings
- Pre-tested against standards
- Safety Gate option ensures safety around entire opening

## Floor Hatch

Part of the KEE HATCH family of products, the FLOOR HATCH Safety Railing is designed for safe egress and ingress through floor access hatches and for protection from the floor opening while the access door is up. It meets OSHA Standards CFR 29 1910.23 and 29 CFR 1910.66.



### Configuration

The railing system uses the industry leading KEE KLAMP components and is easy to assemble. The FLOOR HATCH Safety Railing kits are made with either galvanized 1-1/4" pipe or anodized aluminum 1-1/2" pipe for all hatch sizes. A two sided kit can be ordered for a hatch that backs to the wall. The FLOOR HATCH Safety Railing can also be customized to accommodate a toeboard if needed.

### Installation

For permanent installation, drill 2 holes for each base component (Type 62, Fig 1) and use lag bolts size 3/8" x 2 1/2" and lag shields to fix railing bases in place (lag kits sold separately). For a removable installation, use ground socket components (Type 66, Fig. 2) that are installed flush with concrete.

**Fig. 1**

KEE KLAMP Type 62 - Standard Base Flange for use on solid surfaces



**Fig. 2**

KEE KLAMP Type 66 in-floor base fitting designed for use in concrete. A topside set screw locks the pipe.





# Kee® Dome



skylight guard rail system,  
fits skylights, roof lights, and  
dome lights with curbs

## The Safety Solution for Skylights

Our freestanding KEE DOME system does not penetrate the roof membrane. The heavy duty rubber base keeps the safety railing in place. KEE DOME uses industry leading KEE KLAMP components which are galvanized, making the system long lasting and virtually maintenance free. KEE DOME has been independently tested to OSHA Standard 29 CFR 1910.23.

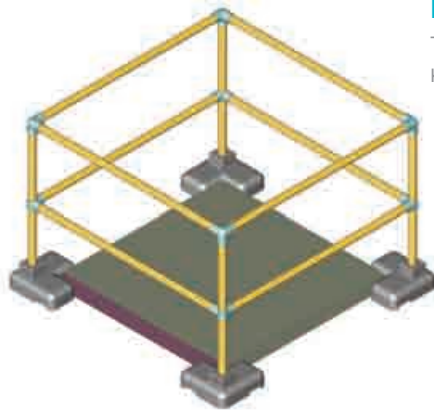
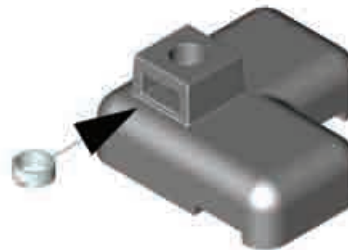

**Fig. 1**

The maximum footprint for Kee Dome is 8' x 8'

**Fig. 2**

A clamping ring is inserted into the base unit to lock the upright



## Configuration

KEE DOME includes upright posts, horizontal rails, and specialized corner connectors or "feet" made of recycled PVC. The upright posts are locked into position within the base units using clamping rings. The resulting structure is safety compliant, remains completely free-standing, and eliminates the risk of damage to the roof membrane.

## Installation

Using standard tools, two workers can install a 8'X 8' KEE DOME in an hour. KEE DOME can be adapted to inclined roofs up to 5 degrees. When installing KEE DOME, all set screws should be tightened to 29 lbs/ft.

## Skylight Fall Protection

- Constructed of rigid galvanized pipe
- KEE DOME does not block light
- Simple customization



## screens



screens for curb style,  
standing seam, and rib/cor-  
rugated metal roof skylights

SKYLIGHT  
SCREENS



## Quality

Made of galvanized or stainless steel, our skylight screens are available in a range of sizes and styles.

- Curb Style: full range of sizes from 12" x 12" to 70" x 120"
- Standing Seam Roofing: applications are 24" x 120"
- Rib/Corrugated Roofing: applications are 36" x 120" to fit a standard 36" x 120" skylight
- Also available in custom sizes

# options



## RAL Color

To enhance visible safety as well as integrate with building aesthetics, KEEGUARD components can be powder coated to match any RAL color.



## Exterior Wall Mount

Two KEE KLAMP Type 68 components or other methods can be employed to attach rail directly to an outer wall. This method is used when equipment or other impediments block the roof edge, not allowing room for our free standing KEEGUARD counterbalance system.



## Grip Tape

Improves grip of existing handrail. Grip Tape has a glow-in-the-dark feature for added safety. Yellow and black coloring is also available.



## Toeboards

Our unique design does not require any drilling on site or in the shop. A slot on the back of the toeboard accepts a bolt head which prevents the bolt from spinning during assembly. Upright hardware and splice kits for corners and straight sections are also available. Toeboard comes in 24' lengths or can be custom cut.



## Parapet Component

A new component designed to retrofit roof parapets that are not compliant with OSHA standards. Rail anchor is angled inward so as not to detract from the aesthetics of your building. KEE KLAMP Type 316.



## Safety Gate

An additional safety feature to your KEE HATCH or KEEGUARD system. Our safety gate has spring hinges and 180° rotation. Installs with simple hand tools to existing uprights.



## Hi-Traction Covers

Improve footing and help prevent slips and falls. Suitable for indoor and outdoor use. Variety of grip options, colors, sizes, and materials. Glow-in-the-dark and custom printing available.

# custom applications



USA  
Kee Safety, Inc.  
100 Stradtman Street  
Buffalo, NY 14206  
Tel: (716) 896 4949  
Fax: (716) 896 5696  
Toll Free: (800) 851 5181

www.keesafety.com  
Email: info@keesafety.com

Canada  
Kee Safety, Ltd.  
40 North Rivermede Road, Units 6 - 7  
Concord, Ontario L4K 2H3  
Tel: (905) 669 1494  
Fax: (905) 669 4347  
Toll Free: (877) 505 5003

Kee Klamp, Kee Lite, Kee Stainless, KeeGuard, Kee Dome, Kee Hatch, Kee Mark, Kee Anchor, Kee Access, KwikKit, Weightanka, Wireanka, BeamClamp, and Box Bolt are all registered trademarks of Kee Safety, Inc. While every effort has been made to ensure the accuracy of the information contained in this brochure, Kee Safety, Inc cannot be held responsible for any errors or omissions. Kee Safety, Inc reserves the right to alter or withdraw products without prior notice. Kee Safety, Inc does not accept responsibility for any loss or damage arising from improper use of its products.

Copyright 2011 Kee Safety, Inc. All Rights Reserved. (Reprint\_V09)

KS/FPC\_US\_V3\_SR/0611